

■ Operating and installation instructions

REMKO MKT ECO series

Local room air conditioner in compact design

MKT 255 ECO, MKT 255 ECO S-Line, MKT 295 ECO, MKT 295 ECO S-Line





Read these operating instructions carefully before commissioning / using this device!

These instructions are an integral part of the system and must always be kept near or on the device.

Subject to modifications; No liability accepted for errors or misprints!

Translation of the original

Table of contents

1	Safety and usage instructions	4
1.1	General safety notes.....	4
1.2	Additional safety notes when handling refrigerant R290.....	4
1.3	Identification of notes.....	5
1.4	Personnel qualifications.....	5
1.5	Dangers of failure to observe the safety notes.....	5
1.6	Safety-conscious working.....	6
1.7	Safety instructions for the operator.....	6
1.8	Safety notes for installation, maintenance and inspection.....	7
1.9	Unauthorised modification and changes.....	9
1.10	Intended use.....	10
1.11	Warranty.....	10
1.12	Transport and packaging.....	10
1.13	Environmental protection and recycling.....	10
2	Technical data	11
2.1	Unit data.....	11
3	Design and function	12
4	Operation	13
5	Assembly and installation	15
6	Commissioning	17
7	Shutdown	17
8	Electrical wiring	18
9	Troubleshooting and customer service	19
10	Care and maintenance	21
11	Exploded view of the unit and spare parts list	22
11.1	Exploded view of the unit.....	22
11.2	Spare parts list.....	23
12	Index	25

REMKO MKT ECO series

1 Safety and usage instructions

1.1 General safety notes

- Carefully read the manual before commissioning the units or their components for the first time. It provides useful tips and notes such as hazard warnings to prevent injury and material damage. Failure to follow the directions in this manual can endanger persons, the environment and the equipment itself or its components and will void any claims for liability.
- Store this manual and the information required for the operation of this system (e.g. refrigerant datasheet) in the vicinity of the units.
- This unit may only be installed and operated as described in this manual.
- Independent conversion and/or modification of any kind is strictly prohibited.
- National regulations in connection with installation must be observed.
- Children must not be left unsupervised when close to the unit.
- For safety reasons, people with mental, physical or other health limitations must not operate this unit unattended.
- The unit is not permitted to be operated with damaged cables. The unit must be repaired by a specialist immediately.
- The unit may only be operated via a power supply with grounding.
- The use of extension cables is not recommended.
- The air filter must be cleaned at intervals of no more than 2 weeks.
- The unit is not permitted to be operated in the vicinity of heat sources.
- The unit must be transported upright. Residue from the condensate must be drained off before transport. The unit must be stood upright for 1 hour prior to commissioning.
- Combustible substances and pressure containers must be kept at least 50 cm from the unit.
- The unit must not be stored and operated in rooms with oil, gas or sulphur.
- The unit must always be switched off with the on/off switch.
- Do not place anything on the device in particular heavy or hot objects.
- Repairs may only be carried out by authorised and certified specialist personnel.
- The unit must not be covered with plastic sheets.
- This unit must be disposed of professionally in accordance with environmental protection.

- The safety notes in regards to the room sizes and the flammability of the refrigerant must not be removed from the machine.
- The units may only be operated in well ventilated areas.
- The unit can be used by children 8 years and up and by persons without physical, mental or other health limitations if this knowledge has been obtained via the necessary safety notes.
- Children must never play with the unit.
- Cleaning the units must not be carried out by children without parental/guardian supervision.

1.2 Additional safety notes when handling refrigerant R290



Warning of inflammable substances!

- The refrigerant R290 fulfils the requirements of the European F-Gas regulation.
- The units contain 0.30 kg of the refrigerant R290.
- The maximum permitted amount of refrigerant R290 is 0.3 kg.
- The units must not be burned, drilled or pierced.
- Only use cleaning agents which have been approved by the manufacturer for cleaning.
- The unit must never be operated in rooms with naked flames (e.g. gas heaters, open fireplaces, etc.).
- Refrigerant circuit components must not be deformed.
- The contained refrigerant R290 is colourless and odourless.
- The unit must not be stored or operated in rooms which have a room area of 14.4 m² or less.
- The accumulation of refrigerant due to leakages can lead to a fire and explosions in rooms which are too small due to the development of heat or ignition sources.
The units must be stored carefully. Mechanical damage must be avoided.

- Intervention in the refrigeration circuit may only be done by certified specialist personnel taking into account the safety notes of the manufacturer.
- Maintenance and repairs may only be carried out by authorised personnel which have the corresponding knowledge in regards to flammable refrigerant.

⚠ WARNING!

Do not use anything other than the agent recommended by the manufacturer to speed up a possible defrosting process or to clean the units. The unit may only be operated and stored in rooms where there are no devices with potential ignition sources. Do not go below the minimum room area of 14.4 m². Note that leaking refrigerant is colourless and odourless. The unit must not be burned or pierced!

1.3 Identification of notes

This section provides an overview of all important safety aspects for proper protection of people and safe and fault-free operation. The instructions and safety notes contained within this manual must be observed in order to prevent accidents, personal injury and material damage.

Notes attached directly to the units must be observed in their entirety and be kept in a fully legible condition.

Safety notes in this manual are indicated by symbols. Safety notes are introduced with signal words which help to highlight the magnitude of the danger in question.

⚡ DANGER!

Contact with live parts poses an immediate danger of death due to electric shock. Damage to the insulation or individual components may pose a danger of death.

⚠ DANGER!

This combination of symbol and signal word warns of a situation in which there is immediate danger, which if not avoided may be fatal or cause serious injury.

⚠ WARNING!

This combination of symbol and signal word warns of a potentially hazardous situation, which if not avoided may be fatal or cause serious injury.

⚠ CAUTION!

This combination of symbol and signal word warns of a potentially hazardous situation, which if not avoided may cause injury or material and environmental damage.

! NOTICE!

This combination of symbol and signal word warns of a potentially hazardous situation, which if not avoided may cause material and environmental damage.



This symbol highlights useful tips and recommendations as well as information for efficient and fault-free operation.

1.4 Personnel qualifications

Personnel responsible for commissioning, operation, maintenance, inspection and installation must be able to demonstrate that they hold a qualification which proves their ability to undertake the work.

1.5 Dangers of failure to observe the safety notes

Failure to observe the safety notes may pose a risk to people, the environment and the units. Failure to observe the safety notes may void any claims for damages.

In particular, failure to observe the safety notes may pose the following risks:

- The failure of important unit functions.
- The failure of prescribed methods of maintenance and repair.
- Danger to people on account of electrical and mechanical effects.

REMKO MKT ECO series

1.6 Safety-conscious working

The safety notes contained in this manual, the existing national regulations concerning accident prevention as well as any internal company working, operating and safety regulations must be observed.

1.7 Safety instructions for the operator

The operational safety of the units and components is only assured providing they are used as intended and in a fully assembled state.

- This unit may only be installed and operated as described in this manual.
- Independent conversion and/or modification of any kind is strictly prohibited.
- Children must not be left unsupervised when close to the unit.
- For safety reasons, people with mental, physical or other health limitations must not operate this unit unattended.
- The unit is not permitted to be operated with damaged cables. The unit must be repaired by a specialist immediately.
- The unit may only be operated via a power supply with grounding.
- The use of extension cables is not recommended.
- The air filter must be cleaned at intervals of no more than 2 weeks.
- The unit is not permitted to be operated in the vicinity of heat sources.
- The unit must be transported upright. Residue from the condensate must be drained off before transport. The unit must be stood upright for 1 hour prior to commissioning.
- Operating the units in rooms with potential ignition sources (naked flames, gas or electrical heaters, fireplaces) is prohibited.
- The unit may only be installed, operated and stored in rooms larger than 14.4 m².
- Protective covers (grilles) over moving parts must not be removed from units that are in operation.
- Do not operate units or components with obvious defects or signs of damage.
- Contact with equipment parts or components can lead to burns or injury.
- The units and components must not be exposed to any mechanical load, extreme levels of humidity or extreme temperatures.
- Never drill through the housing cover or have the unit come into contact with fire.
- Rooms in which refrigerant may escape must be adequately aerated and ventilated. Otherwise there is danger of suffocation.

- All housing parts and unit openings, e.g. air inlets and outlets, must be free from foreign objects, fluids or gases.
- The local room air conditioners are designed for flexible use in living and work spaces. Year-round operation is not recommended. Use in server rooms is prohibited.
- Do not leave the units running for an extended period unsupervised.

Improper use can cause serious damage to the unit.

Read this manual carefully before commissioning!

The unit and in particular the control panel must not come into contact with water.



Never cover the air inlets and outlets.



Do not allow children to play with the unit



Do not stand or sit on the unit.



Unplug the power plug before cleaning the unit.



Do not disassemble housing parts (consult a specialist company).



Unplug the power plug when not in use for a long period.



Ensure the voltage is correct (220-240 V AC, 50 Hz).



Do not operate the unit with defective cables or sockets.

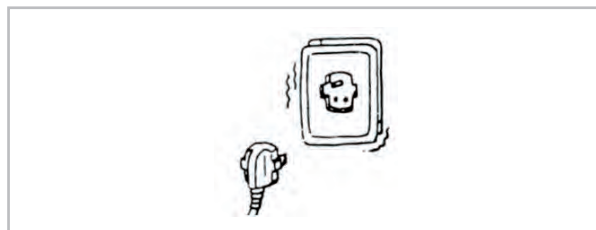

1.8 Safety notes for installation, maintenance and inspection

■ Check the work area

Before starting work on units with combustible refrigerants, ensure that any potential ignition sources are removed and the risk of igniting the refrigerants is eliminated. The aforementioned safety notes for repairing the units must be observed at all times. Work may only be carried out by authorised specialist personnel with knowledge of handling combustible refrigerants!

■ Prepare the work area

Any persons present must be informed about the repair process accordingly and persons not involved must vacate the work area. Working in rooms with limited space is prohibited. Ensure that sufficient space is available at the workplace. Ensure that the ambient conditions are suitable for working with combustible refrigerants.

■ Identify refrigerant leaks, check the atmosphere

Refrigerant may unexpectedly escape when working on the refrigerant circuit. Ensure that the atmosphere in the workplace is not combustible at all times by using suitable refrigerant detectors. Be sure to ensure that the refrigerant detector used is suitable, approved and calibrated for use with refrigerant R290.

■ Provide fire extinguishers

Provide appropriate fire extinguishers before starting work. For this purpose, dry powder or CO₂ fire extinguishers are suitable.

■ Remove any potential ignition sources

Leaking refrigerant in combination with corresponding ignition sources can lead to an explosion. All ignition sources must therefore be kept away from the working area at all times! This also includes the smoking of cigarettes. Inform all persons present that this includes the affixing of safety notes and the closing off of the working area.

REMKO MKT ECO series

■ Sufficient ventilation

Before starting work, ensure that the working area is outdoors or has sufficient ventilation. A continuous ventilation stream is required while working. The safety of the persons working must be guaranteed by the exhaust air equipment: potentially leaking refrigerant must be lead away safely and drained into the atmosphere in an optimum manner.

■ Checking the refrigerant circuit

If electronic components need to be replaced, ensure that the spare parts have the same function and identical technical specifications. The maintenance and replacement regulations of the manufacturer must always be observed and complied with. Please contact the support of the manufacturer with any problems or queries. The following safety checks must be carried out when using combustible refrigerants:

- The fill level adjusts to the size of the rooms in which the unit is located.
- The exhaust air equipment and its outlets function properly and are not blocked or obstructed.

■ Checking the electronic components

A component and safety check must be carried out before repairing and maintaining electronic components. If safety cannot be ensured due to a defect on a component, installation must not take place until safety can be guaranteed again. If the defect on the spare part cannot be remedied and downtime of the unit is no longer acceptable, an adequate temporary solution must be arranged. The owner/operator of the unit must be informed about this. The detailed safety check must include the following aspects:

- Capacitors are discharged. Discharging must be done in a safe process to prevent flying sparks.
- There must be no electronic components active or uninsulated wires while filling, repairing or cleaning.
- There must be no earthing of the system.

■ Repairs to closed components

Before repairing closed components/housing parts, the unit must be free from voltage. If carrying out the repairs free from voltage cannot be avoided, the critical points of potential refrigerant leakages must be checked using a leak detector.

The following notes must be observed when working on electronic components if the housing is changed in such a way that its safety is influenced. This also relates to cases where the lines are damaged, there is excessive or incorrect pin assignment, connections are not assigned in the original way or similar deviations to the expected condition are determined.

■ Repairing of intrinsically safe components

Do not introduce permanent inductive or capacitive loads into the existing circuits without ensuring that the maximum permitted voltages and amperages of the assemblies and lines are not exceeded. Intrinsically safe components are individual components that can be operated in the presence of flammable substances. The test equipment must be adjusted according to the situation-dependent conditions. Only use components which are officially approved by the manufacturer as spare parts. Unapproved components can cause a fire in the event of a leakage in the refrigerant circuit.

■ Wiring

Lines must be checked for the following damage:

- Damage to the insulation
- Corrosion at the contact points
- Excessive pressure on the lines
- Damage due to vibrations
- Damage due to sharp edges
- Damage due to other influences not mentioned here

Also consider the ageing of the material and continuous vibration loads due to compressors or fans when checking.

■ Identify combustible refrigerant

Do not use any potential ignition source when searching for refrigerant leaks under any circumstance. The use of a leak detection lamp or other similar devices with a naked flame is not permitted.

1. Ensure that the components are installed correctly.
2. Ensure that sealing materials are not changed in such a way that combustible gases or objects could penetrate into the interior of the components.
3. Spare parts must correspond to the manufacturer's specifications.

! NOTICE!

The use of silicones can influence the effectiveness of leak detection devices! Intrinsically safe components must not be insulated before starting work.

■ Leak detection methods

The following leak detection methods are permitted for systems with combustible refrigerants. Electronic equipment must be used for detecting leaks. These must be selected with the sensitivity matched to the situation and recalibrated if necessary (calibration must take place in a refrigerant-free environment). The leak detection device must be adjusted to the lowest flammability limit (LFL) of the refrigerant. Liquid leakage instruments are permitted for most refrigerants. Chlorinated substances are the exception here as the chlorine in combination with the refrigerants can cause corrosion on the copper cables. If a leak is detected, all potential open ignition sources must be removed immediately. If a leak has been detected in the system which requires reworking of the piping in the form of soldering, the system must be completely free of refrigerant or, if possible, the affected part disconnected from the system using stopcocks. The affected system parts must be flushed with oxygen-free nitrogen run before and during the repair work.

■ Emptying and evacuating the system

If the refrigerant circuit must be opened for repairs or other reasons, this must be carried out in a safe and professional way. In any event, proceed with extreme caution since ignition may occur at any time! Stick to the following procedure:

1. Drain the refrigerant
2. Flush the system with inert gas
3. Evacuate
4. Repeat steps 2 to 3 if required
5. Opening the system by cutting or soldering

The system must be flushed with oxygen-free nitrogen in order to guarantee safety. The flushing process must be repeated multiple times if necessary. Do not use compressed air or oxygen for the flushing process! After evacuating, flushing takes place by filling with dried nitrogen until the operating pressure is reached and then the system must be evacuated again. This flushing process must often be repeated until there is no more refrigerant in the system. After the last flushing, the system must be brought to the ambient pressure in order to start work. The flushing process is indispensable when soldering work is required on the piping. Ensure that the vacuum pump outlet is not near an ignition source and continuous ventilation is guaranteed.

■ Filling process

The following requirements for the general specifications must also be fulfilled during the filling process:

- Ensure that no contamination occurs from other refrigerants (residues in the filling equipment).
- Keep the lines as short as possible to minimise the likelihood of residues forming.
- Filling bottles and cylinders must be stood upright.
- Ensure that the system is earthed before filling.
- Label the system with the refrigerant type designation after filling
- Never exceed the maximum fill level.

The system must be checked for leaks (pressure test!) before filling. The system must be checked for leaks once more after filling and before commissioning. Check for leaks again when leaving the work space.

■ Labelling when shutting down

If a unit must be taken out of operation and the refrigerant must be disposed of, the unit must be labelled with the date and a signature. Ensure that the note remains attached to the combustible refrigerant.

■ Transportation of units which contain combustible refrigerants

National provisions must be observed.

■ Storing of units which contain combustible refrigerant

National provisions must be observed.

■ Transportation without the original packaging

If the units are transported without the original packaging, they must be packed in such a way that mechanical damage is prevented. The units must be transported upright.

1.9 Unauthorised modification and changes

Modifications or changes to units and components are not permitted and may cause malfunctions. Safety devices may not be modified or bypassed. Original replacement parts and accessories authorised by the manufacturer ensure safety. The use of other parts may invalidate liability for resulting consequences.

REMKO MKT ECO series

1.10 Intended use

Depending on the model, the equipment and the additional fittings with which it is equipped is only intended to be used as an air-conditioner for the purpose of cooling or heating the air in an enclosed room..

Different or additional use shall not be classed as intended use. The manufacturer/supplier assumes no liability for damages arising from an unintended use of the equipment. The user bears the sole risk in such cases.

Using the equipment as intended also includes working in accordance with the operating manual and installation instructions and complying with the maintenance requirements.

Under no circumstances should the threshold values specified in the technical data be exceeded.

1.11 Warranty

For warranty claims to be considered, it is essential that the ordering party or its representative complete and return the "certificate of warranty" to REMKO GmbH & Co. KG at the time when the units are purchased and commissioned.

The warranty conditions are detailed in the "General business and delivery conditions". Furthermore, only the parties to a contract can conclude special agreements beyond these conditions. In this case, contact your contractual partner in the first instance.

1.12 Transport and packaging

The devices are supplied in a sturdy shipping container. Please check the equipment immediately upon delivery and note any damage or missing parts on the delivery and inform the shipper and your contractual partner. For later complaints can not be guaranteed.

WARNING!

Plastic films and bags etc. are dangerous toys for children!

Why:

- Leave packaging material are not around.
- Packaging material may not be accessible to children!

1.13 Environmental protection and recycling

Disposal of packaging

All products are packed for transport in environmentally friendly materials. Make a valuable contribution to reducing waste and sustaining raw materials. Only dispose of packaging at approved collection points.



Disposal of equipment and components

Only recyclable materials are used in the manufacture of the devices and components. Help protect the environment by ensuring that the devices or components (for example batteries) are not disposed in household waste, but only in accordance with local regulations and in an environmentally safe manner, e.g. using certified firms and recycling specialists or at collection points.



2 Technical data

2.1 Unit data

Series		MKT 255 ECO	MKT 255 ECO <i>S-LINE</i>	MKT 295 ECO	MKT 295 ECO <i>S-LINE</i>
Operating mode		Local compact air conditioning unit for cooling			
Nominal cooling output ¹⁾	kW	2.6		2.9	
Energy efficiency ratio - cooling		A			
Energy efficiency rating EER ¹⁾		2.6			
Energy consumption, hourly	kWh/60 min	1.0			
Application area (room volume), approx.	m ³	80		90	
Adjustment range indoor unit	°C	+16 to +32			
Operating range - indoor unit	°C/%r.H.	+16 to +35/35 to 85			
Refrigerant		R290			
Refrigerant, basic quantity	kg	0.30			
CO ₂ equivalent	t	0.00			
Max. operating pressure / cooling cycle	kPa	1160/4120			
Air flow volume per stage	m ³ /h	230/290/325		260/330/340	
Sound pressure level per stage ²⁾	dB(A)	49/50/51			
Sound power level max.	dB(A)	65			
Power supply	V/Ph/Hz	230/1~/50			
Enclosure class	IP	X0			
Electrical rated power consumption ¹⁾	kW	1.0		1.1	
Electrical rated power consumption ¹⁾ Standby operation	W	0.39		0.38	
Electr. rated current consumption ¹⁾	A	4.49		4.54	
Elec. starting current max., LRA	A	17			
Exhaust air hose, length / diameter	mm	1500/150			
Dimensions - height/width/depth	mm	745/455/395			
Weight	kg	30.5		32.0	
Standard colour		white	silver	white	silver
Serial number		1922...	1923...	1924...	1925...
EDP no.		1616255	1616256	1616295	1616296

¹⁾ Room air temperature TK 35 °C, FK 24 °C

²⁾ Distance 1 m free field

REMKO MKT ECO series

3 Design and function

Unit description

The local air conditioning unit is particularly well suited to flexible use.

The local room air conditioner comprises a floor-standing unit for the indoor area and an exhaust air hose to conduct the heat away. The indoor unit extracts the heat from the room to be cooled by means of an evaporator (heat exchanger) and transfers it to the internal cooling cycle. This releases the heat back to the outside via another heat exchanger (condenser) by means of the flexible exhaust air hose.

The condensate arising during cooling mode is continually drained off via the condenser by means of a condensate pump located in the unit - the condenser evaporates the condensate and discharges it to the outside via the exhaust air hose.

The unit filters and dehumidifies the air thereby creating a comfortable room climate. It works fully automatically and offers numerous additional options thanks to its microprocessor controller. The operation of the unit can be conveniently operated by means of the infra-red remote control included.



Fig. 1: Front view

- A: Air outlet, recirculation
- 1: Recessed grip
- 2: Control panel
- 3: Ventilation louvres
- 4: Transport castors

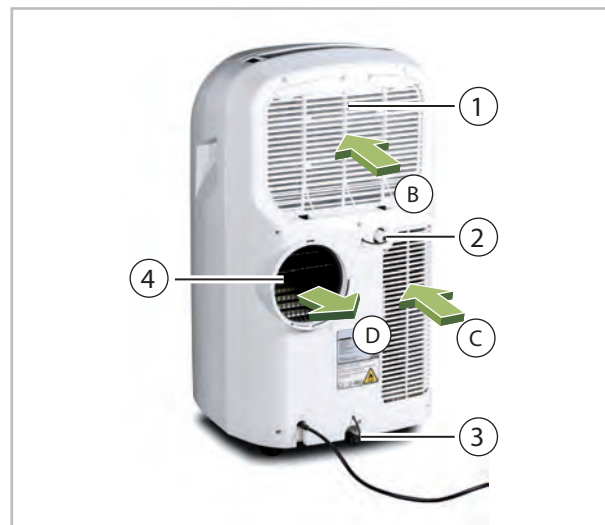

Fig. 2: Rear view

- B: Air inlet, recirculation
- C: Air inlet, exhaust air
- D: Air outlet, exhaust air
- 1: Air filter, recirculation
- 2: Condensate drainage with stopper
- 3: Condensate emergency drainage with stopper
- 4: Exhaust air hose connection

4 Operation

The system can be operated by means of the control panel on the unit or via the standard infrared remote controller. The functional operation of the keys is identical, however, the designation may vary. The batteries must be correctly inserted before the infrared remote control is used.

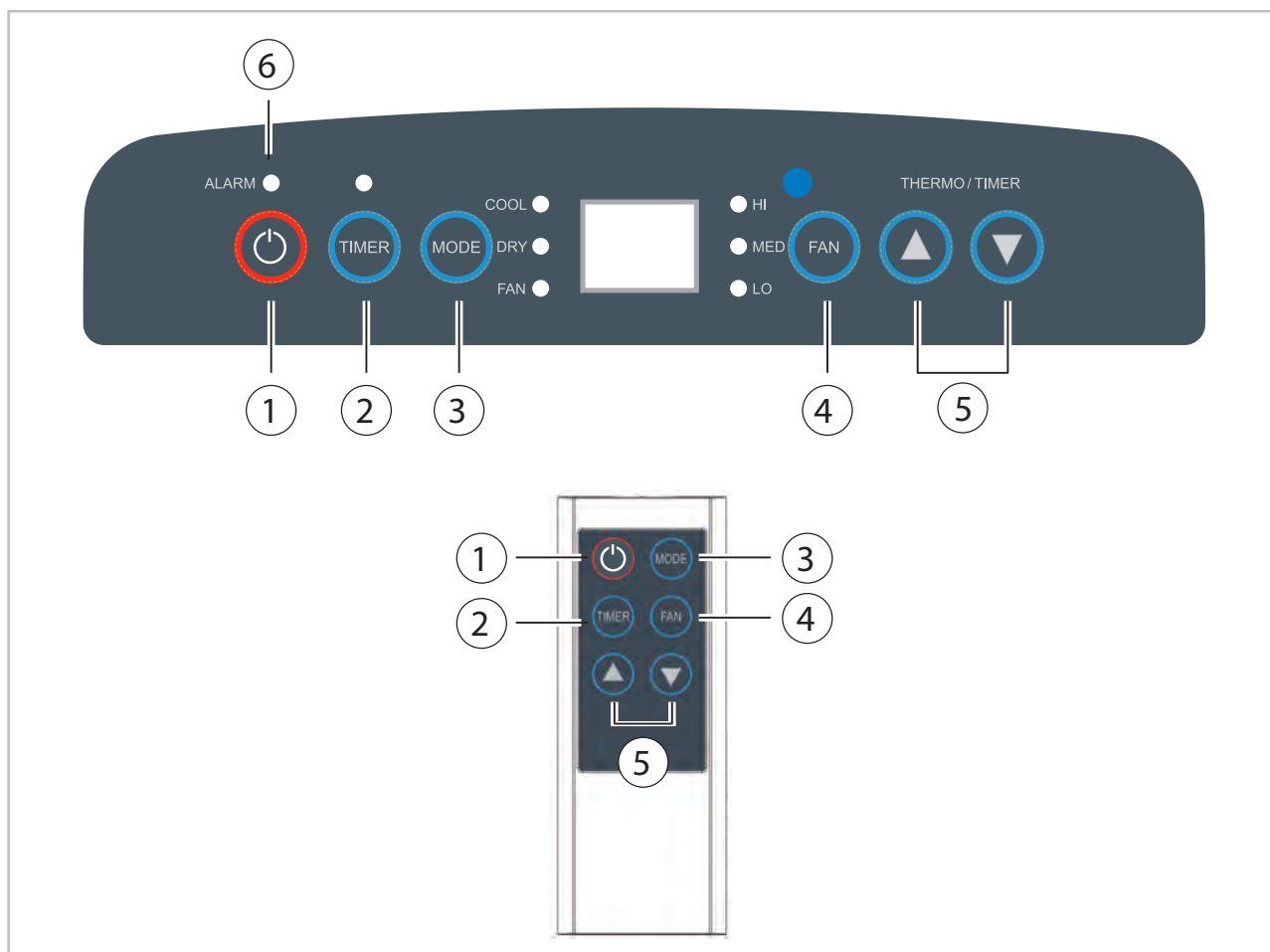

Fig. 3: Remote control and control panel

Legend

① **Key  (On/Off)**

This key switches the unit on or off.

② **Operating mode "MODE" key**

Actuation of this key allows the operator to select between the cooling mode (COOL), dehumidification mode (DRY) or circulated air mode (FAN). The LEDs indicate the selected operating mode.

③ **"FAN" speed key**

With this key it is possible to set the fan speed and therefore the air flow. It is possible to select between the speed stages low (LO), medium (MED) and high (HI). The LEDs show the selected fan speed.

④ **"TIMER" key**

This key can be used to activate a switch-on or switch-off delay. The switch-on delay is activated when the unit is switched on, whilst the switch-off delay is activated when the unit is switched off. Using the arrow keys, it is subsequently possible to set the desired delay in 1-hour steps. If no further change is made for a few seconds, the unit saves the setting and the set time is shown on the display. The LED lights up when the timer is activated.

REMKO MKT ECO series

⑤ "▲/▼ - THERMO/TIMER CONTROL" keys

The target temperature can be set by pressing the "▲/▼" keys. This can be adjusted in a range of 16 to 32 °C in 1 °C steps.

⑥ "ALARM" display

The condensate arising will be collected in an internal reservoir, fed to the condenser and evaporated there. The evaporated condensate will then be fed to the outside via the exhaust air hose. If the condensate cannot be fed away then a fault shut-down is initiated along with an LED ⑥ signalling this. In order to put the unit back into operation again after this fault shut-down, proceed as follows:

1. ➤ Switch the unit off with the "I/O" key and pull out the power plug.
2. ➤ Place a suitable container underneath the condensate drain of the internal reservoir. The condensate drain is located on the lower centre on the rear of the unit.
3. ➤ Pull out the stopper from the condensate drain and collect the condensate that drains out.
4. ➤ Then insert the stopper once again.

! NOTICE!

You will achieve a pleasant room temperature if you set the desired target temperature max. 4 to 7 °C below the outside temperature.

Infrared remote control

General notes

- With the unit switched on any change to the settings will be automatically transferred to the room air conditioner. The proper receipt of data will be acknowledged with an audible "beep".
- To operate the infrared remote control it should be pointed towards the receiver. The receipt of data is only possible if there are no objects between the transmitter and the receiver.
- If the system is shut down for an extended period it is advisable to remove the batteries from the remote control.

! NOTICE!

Never use new and used batteries at the same time, remove discharged batteries immediately and replace these with new batteries of the prescribed quality as there is a danger of discharged batteries leaking.

Inserting the batteries into the remote control

Before initial commissioning, insert the supplied batteries (2 each, type AAA) into the remote control.

1. Slide the battery compartment cover on the rear of the remote control to open it.
2. Insert the batteries with the correct polarity. Observe marking in the battery compartment.
3. Close the battery compartment again.



Help save on energy consumption in stand-by mode! If the device, system or component is not in use, we recommend disconnecting the power supply. Components with a safety function is excluded from our recommendation!

5 Assembly and installation

Assembly and unit installation instructions

The unit is positioned at the desired location with the discharge side pointing into the room. When positioning, observe the following instructions:

- After unpacking the unit let it sit on its transport rollers for at least 5 minutes before you switch it on.
- Set the unit down in a stable position on a level and firm floor. If the floor is uneven then this can lead to vibrations and disturbing noises.



Fig. 4: Unit installation

! NOTICE!

There must be a minimum clearance of 20 cm between the rear of the unit and the wall.

- All extensions to the power supply must be of a sufficient cable size and must only be used fully rolled out.



Fig. 5: Power supply

- Check whether the stopper in the condensate drain is present and correctly installed. There is a risk of uncontrolled condensate leakage after commissioning.



Fig. 6: Condensate drain

- 1: Condensate drainage with stopper
- 2: Condensate emergency drainage with stopper

- Never operate the unit without the air inlet filter. Otherwise, the fins of the heat exchanger can become dirty and the unit loses performance.



Fig. 7: Recirculated air filter

- 1: Recirculated air filter
- Ensure that persons and sensitive objects, such as plants, are not placed directly in the air flow emerging from the unit.



In addition, with direct solar radiation close the curtains and blinds and keep the windows and doors closed during operation.

REMKO MKT ECO series

Conduct the warm exhaust air away

! NOTICE!

The exhaust air hose should always be laid rising in the direction of air flow and must not be extended!

In cooling mode the unit creates warm moist exhaust air, which must be conducted away from the room to be cooled. For this reason it is necessary to plug the exhaust air hose into the outlet opening on the rear of the unit.

- Ensure that the catches for the exhaust air hose latch securely into the two openings of the connection aperture. Do not lay the flexible exhaust air hose with tight bends and do not kink it in order to be sure of effective operation and to avoid this causing damage to air ducting components!



Fig. 8: Latch the hose into place

- The exhaust air of the unit contains a certain amount of moisture. For this reason it is advisable to feed the exhaust air to the outdoor area or to outdoors.

Exhaust air routing variants

You can route the exhaust air out of the building as follows:

Via a flat nozzle

The flat nozzle supplied can be used in various different ways. It is possible to feed the flat nozzle through an open window and fasten it by means of Velcro and a window suction cup (Fig. 9). Likewise the flat nozzle can be hung in a tilted window (Fig. 10).

Via a wall pass-through

The hose supplied is firmly attached to a wall pass-through. A suitable wall pass-through is available as an accessory (Fig. 11).

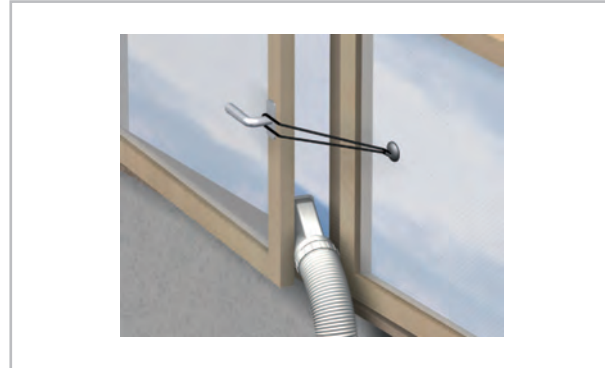

Fig. 9: Exhaust air with open window

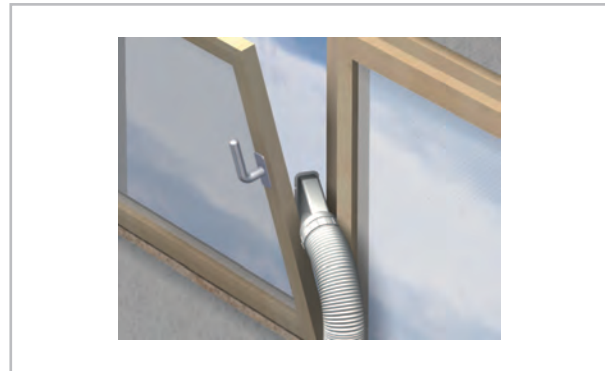

Fig. 10: Exhaust air with tilted window



Fig. 11: Wall pass-through

! NOTICE!

In some circumstances routing the exhaust air via a firmly attached exhaust air hose, e.g. through closed doors or windows, can lead to negative pressure in the room in which the unit is being used. If this should reduce the performance of the unit then arrange for the pressure to be equalised (provide ventilation if necessary on-site).

6 Commissioning

Before every commissioning the air inlet and outlet openings should be checked for foreign bodies and the air inlet filter must be checked for dirt. Blocked or soiled grills and filters must be cleaned immediately, see "Care and maintenance" chapter.

Cooling mode

1. ➤ Switch the unit on with the "I/O" key.
2. ➤ Select cooling mode with the "MODE" key.
3. ➤ Set the desired target temperature with the "THERMO/TIMER CONTROL" keys. The selected target temperature will be shown in the display. If the fan speed selected is too large or too small then this can be adjusted with the "FAN" key.

Recirculation mode

1. ➤ Switch the unit on with the "I/O" key.
2. ➤ Select recirculation mode with the "MODE" key.

7 Shutdown

! NOTICE!

Never switch off the equipment by pulling out the mains plug.

Temporary shutdown

If it is planned to shut down the unit for longer periods e.g. during the winter, proceed as follows:

1. ➤ Let the unit run in recirculating operation for ca. 2 hours in order to dry the surfaces of the evaporator fins. This will transport the remaining moisture out of the unit and this will avoid unpleasant odours when the unit is re-commissioned.
2. ➤ Switch the unit off with the "I/O" key, pull out the power plug and wind up the power supply. Ensure that the cable is not kinked or too severely bent. The line can be fastened to the rear of the unit.
3. ➤ Place a suitable container underneath the condensate drain of the internal reservoir. The condensate drain is located on the lower rear side of the unit.
4. ➤ Pull out the stopper from the condensate drain and collect the condensate that drains out.
5. ➤ Then insert the stopper once again. A missing stopper or an incorrectly inserted stopper will result in condensate leaking out after re-commissioning.
6. ➤ Store the unit in an upright position in a cool, dry and dust-free location protected from direct sunlight. Cover the unit with a synthetic cover to protect it against dust if desired.

Permanent shutdown

The entire system should only be dismantled by a specialist firm familiar with all environmental aspects involved. REMKO GmbH & Co. KG or your contractual partner will be pleased to provide a list of refrigerant specialists in your area.

REMKO MKT ECO series

8 Electrical wiring

Electrical wiring diagram

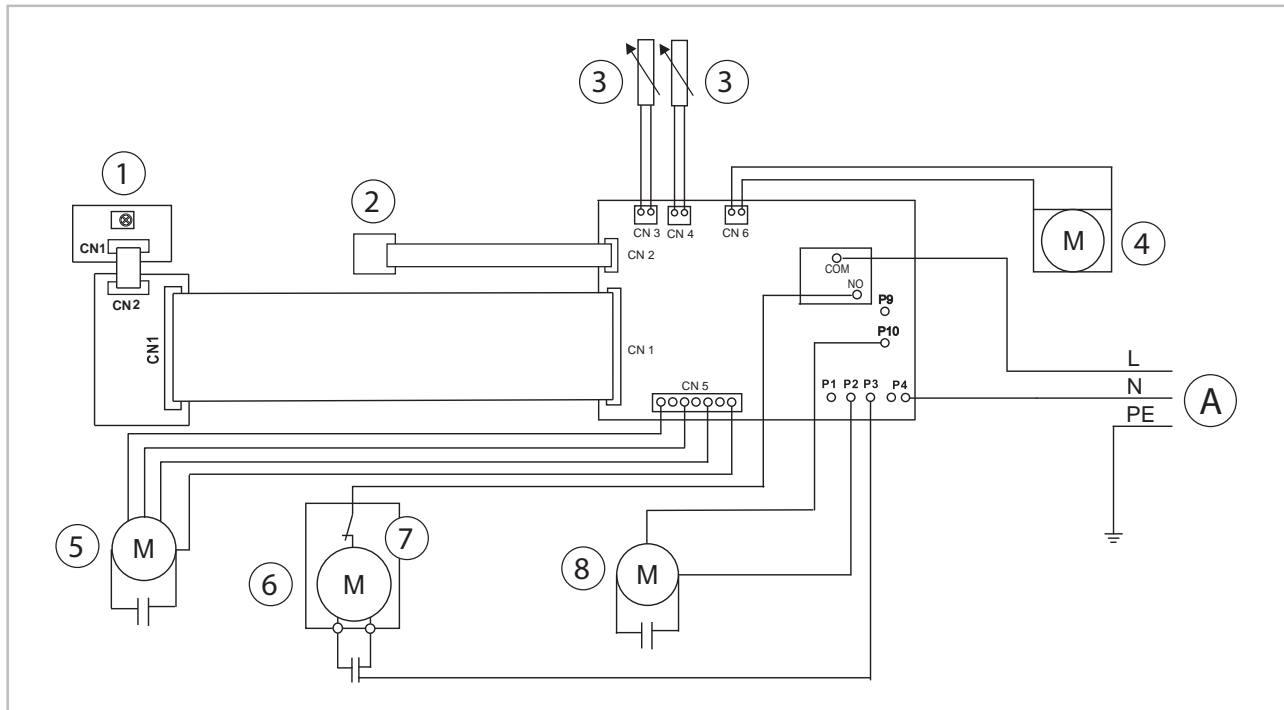

Fig. 12: Electrical wiring diagram

- | | |
|------------------------|--------------------------------------|
| A: Power supply | 5: Fan motor, evaporator |
| 1: Infrared receiver | 6: Compressor |
| 2: Liquid level switch | 7: Compressor overheating protection |
| 3: Temperature probe | 8: Fan motor, condenser |
| 4: Condensate pump | |

9 Troubleshooting and customer service

The unit has been manufactured using state-of-the-art production methods and has been tested several times to ensure that it works properly. If malfunctions should occur, please check the unit as detailed in the list below. Please inform your dealer if the unit is still not working correctly after all the function checks have been performed.

Operational malfunctions

Fault description	Cause	Remedy
The unit does not start or switches itself off.	Master switch off.	Switch on the master switch.
	Power failure	Check voltage and if necessary wait until turned on again
	Defective mains fuse	Arrange to have exchanged
	Power supply defective	Repair by specialist firm.
	Operational temperature range too low or exceeded.	Observe operational temperature range 16 to 35 °C.
	Internal reservoir full.	Empty reservoir.
	The ambient temperature of the unit lies outside the operating range (16 to 35 °C).	Do not operate the unit outside the operating range.
The unit does not work or works at reduced cooling capacity.	Exhaust air hose kinked, extended, routed downwards or blocked.	Ensure that there is a clear path for the exhaust air.
	Filter contamination, inlet and/or outlet blower openings blocked by foreign bodies.	Clean filter.
	Minimum clearances too small.	Observe minimum clearances.
	Windows and doors open/heat load was increased.	Close doors and windows/ reduce heat load.
	Negative pressure in the installation room whilst the unit is operating with wall pass-through.	Balance out pressure in the installation room.
	"Cooling" operating mode is not selected.	Set "Cooling" operating mode.
	Unit will be switched by means of the timer function.	Press "I/O" key again.
	Temperature setting too high.	Reduce temperature.
	Overvoltage due to local lightning strike.	Switch unit off and separate from the power supply for 5 mins., then start anew.
The unit does not respond to the infra-red remote control.	Batteries in the remote control are empty or the distance to the receiver is too great.	Insert new batteries/reduce distance.
	After battery exchange, incorrect polarity of batteries.	Insert the batteries with the correct polarity. Observe marking.

REMKO MKT ECO series

Fault description	Cause	Remedy
Condensate discharge on unit.	Unit standing at an angle.	Stand vertically.
	The stopper for the condensate drain is not correctly inserted or is damaged.	Insert stopper correctly or replace if necessary.

Error indication by code

Error code	Error description	Error elimination
E1	Ambient temperature probe defective	Replace probe
E2	Probe, evaporator defective	Replace probe
E5	Control board defective	Replace the control board

10 Care and maintenance

Regular care and observation of some basic points will ensure trouble-free operation and a long service life.

DANGER!

Prior to performing any work, ensure the equipment is disconnected from the voltage supply and secured to prevent accidental switch-on!

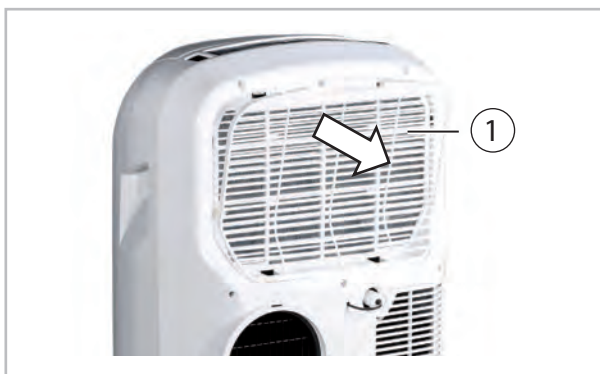

Fig. 13: Filter removal

1: Recirculated air filter

- Clean the unit using a damp cloth. Do not use a jet of water.
- Do not use any caustic, abrasive or solvent-based cleaning products.
- Only use suitable cleaning agents, even in the event of severe soiling.
- Ensure that no moisture gets into the unit. Clean the exhaust air and outlet openings regularly and thoroughly. This is where dirt most often collects first

NOTICE!

Check the level of dirt on the on the exchanger fins.

- Clean the air filter on the indoor unit at regular intervals, and more frequently if necessary.
- It is recommended that you take out a maintenance contract with an appropriate specialist firm.



This enables you to ensure the operational reliability of the plant at all times!

Filter cleaning

The unit is equipped with an air filter. This can be withdrawn from the rear of the unit. The filters must be cleaned at regular intervals. Clean the air filters at intervals of no more than 100 operating hours. Reduce this interval in the case of heavily contaminated air.

Please proceed as follows in order to clean the unit:

1. ➤ Switch the unit off and pull out the power plug.
2. ➤ Pull the filter out of the unit (Fig. 13).
3. ➤ Clean the dust off the filter. Use a vacuum cleaner in the event of slight soiling.
4. ➤ In the case of heavy soiling clean the filter carefully in lukewarm water.
5. ➤ Then allow the filter to dry in the air.
6. ➤ Insert the filter back into the unit.
7. ➤ Ensure that the filter is dry and undamaged.

NOTICE!

Never operate the indoor unit without the original filter. The heat exchanger fins on the indoor unit with soil up if operated without a filter and the device will suffer performance loss.

REMKO MKT ECO series

11 Exploded view of the unit and spare parts list

11.1 Exploded view of the unit

MKT 255 ECO, MKT 255 ECO *S-LINE*, MKT 295 ECO, MKT 295 ECO *S-LINE*

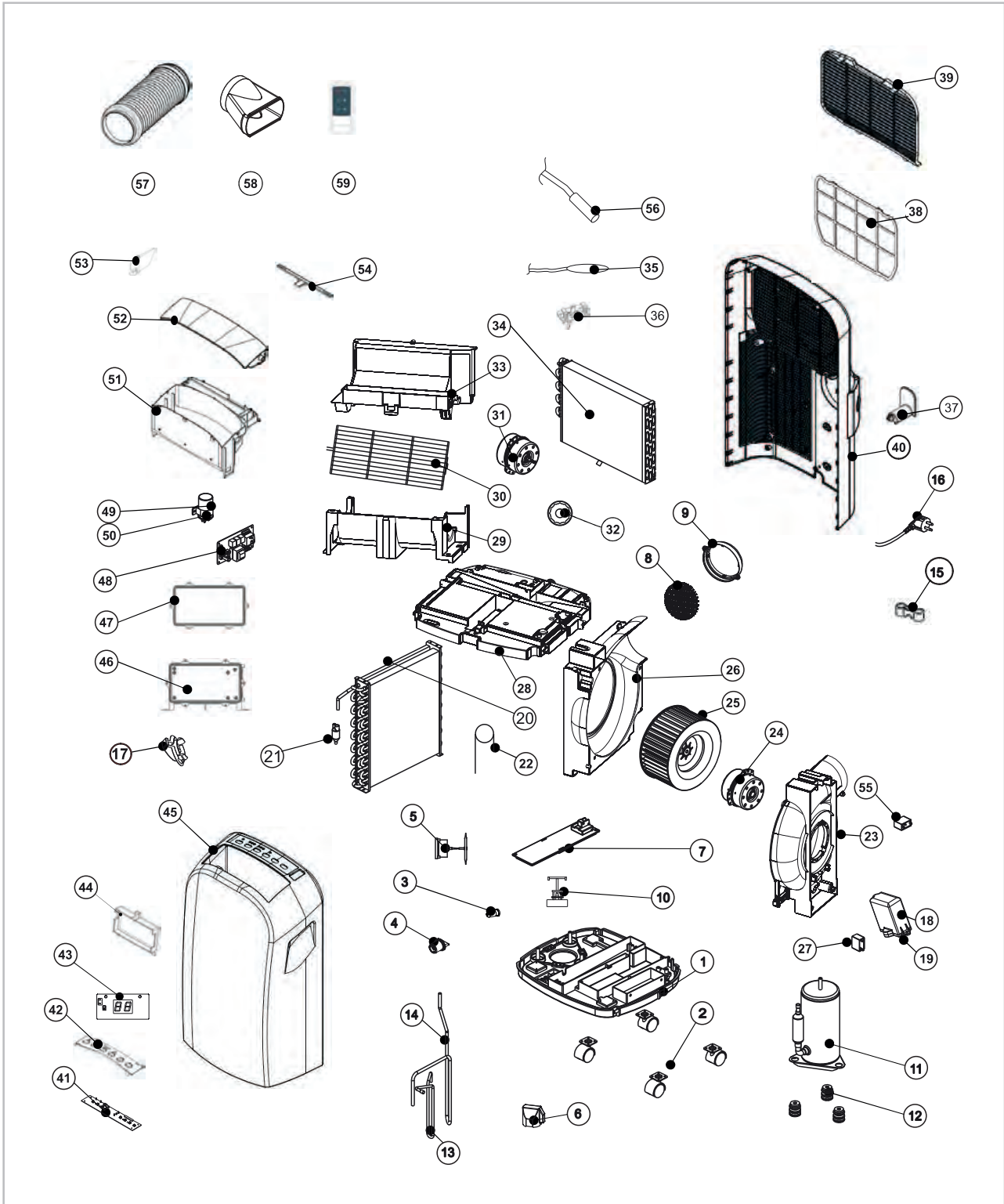

Fig. 14: Exploded view

11.2 Spare parts list

Please contact REMKO GmbH & Co. KG directly to order spare parts.
All the spare part numbers for your unit can be found in the download area at www.remko.de.



IMPORTANT!

To ensure the correct delivery of spare parts, please always the device type with the corresponding serial number (see type plate)

No.	Designation	MKT 255 ECO, MKT 255 ECO <i>S-LINE</i> , MKT 295 ECO, MKT 295 ECO <i>S-LINE</i>
1	Base plate	On request by providing the serial number
2	Conveyor rollers	
3	Rubber stopper	
4	Sealing cap	
5	Condensate pump	
6	Protective cap	
7	Condensate tray cover	
8	Protection grid hose connection	
9	Exhaust air hose connection nozzle	
10	Liquid level switch	
11	Compressor	
12	Vibration dampers	
13	Hot gas line	
14	Suction pipe	
15	Power supply cable strain relief	
16	Power supply cable with Schuko plug	
17	Exhaust air hose interlock	
18	Capacitor cover	
19	Capacitor box fastening	
20	Condenser	
21	Venturi distributor	
22	Capillary tube injection	
23	Housing part, exhaust air fan right	
24	Exhaust air fan motor	
25	Exhaust air fan wheel	
26	Housing part, exhaust air fan left	
27	Capacitor for exhaust air fan motor	
28	Housing intermediate part	

REMKO MKT ECO series

No.	Designation	MKT 255 ECO, MKT 255 ECO <i>S-LINE</i> , MKT 295 ECO, MKT 295 ECO <i>S-LINE</i>
29	Housing part, recirculating fan motor bottom	On request by providing the serial number
30	Protection grid recirculating fan	
31	Recirculating fan motor	
32	Fan bearing	
33	Housing part, recirculating fan motor top	
34	Evaporator	
35	Temperature probe, recirculation	
36	Recirculation probe fastening	
37	Power supply cover	
38	Air filter	
39	Air filter cover	
40	Unit rear	
41	Display board	
42	Operating panel	
43	Display circuit board	
44	Display board cover	
45	Housing front	
46	Board housing cover	
47	Board housing	
48	Control board	
49	Compressor capacitor	
50	Capacitor compressor fastening clip	
51	Housing part air outlet, recirculation	
52	Air deflection blade, horizontal	
53	Air deflection blade, vertical	
54	Shift lever for air deflection blade	
55	Capacitor, recirculating fan motor	
56	Air humidity probe	
57	Exhaust air hose	
58	Window nozzle	
59	Infrared remote control	

We reserve the right to modify the dimensions and design as part of the ongoing technical development process.

12 Index

A

Assembly 15

C

Care and maintenance 21

Cleaning the filter 21

Condensate drain 15

Conduct the warm exhaust air away 16

D

Disposal of equipment 10

E

Electrical wiring diagram 18

Environmental protection 10

Exhaust air routing variants

 Via a flat nozzle 16

 Via a wall pass-through 16

Exploded view 22

Exploded view of the unit 22

I

Installation 15

M

Maintenance 21

O

Operation

 Control panel 13

R

Recirculated air filter 15

S

Safety

 Dangers of failure to observe the safety

 notes 5

 General 4

 Identification of notes 5

 Note for inspection work 7

 Note for installation work 7

 Note for maintenance work 7

 Notes for the operator 6

 Personnel qualifications 5

 Refrigerant R290 4

 Safety-conscious working 6

 Unauthorised modification 9

 Unauthorised replacement part manufacture . 9

Set-up 15

W

Warranty 10

REMKO MKT ECO series

REMKO QUALITY WITH SYSTEMS

Air-Conditioning | Heating | New Energies

REMKO GmbH & Co. KG
Klima- und Wärmetechnik

Im Seelenkamp 12
32791 Lage

Telephone +49 (0) 5232 606-0
Telefax +49 (0) 5232 606-260

E-mail info@remko.de
URL www.remko.de

Hotline within Germany
+49 (0) 5232 606-0

Hotline International
+49 (0) 5232 606-130

